

# IOM17 and IOM27 Input/Output Module Installation Instructions

MS-IOM1711 Series, MS-IOM2711 Series

Part No. 24-10144-76, Rev. M  
Issued March 2016

Refer to the [QuickLIT website](#) for the most up-to-date version of this document.

## Application

The IOM17 and IOM27 field controllers are part of the Metasys® system Field Equipment Controller family. Input/Output Module (IOM) controllers expand the number of points connected to a Network Automation Engine (NAE), Network Control Engine (NCE), Field Equipment Controller (FEC), or Advanced Application Field Equipment Controller (FAC) to monitor and control a wide variety of HVAC equipment.

IOM field controllers operate on an RS-485 BACnet® Master-Slave/Token-Passing (MS/TP) Bus as BACnet Application Specific Controllers (B-ASCs) and integrate into Johnson Controls® and third-party BACnet systems.

**Important:** In Metasys system smoke control applications, use only the MS-IOM1710-0U and MS-IOM2710-0U models that are UL Listed, UUKL/UUKLC 864 Listed, Smoke Control Equipment. For Metasys system smoke control applications, you must refer to the *Metasys System UL 864 Ninth Edition UUKL/UUKL7 Smoke Control System Technical Bulletin (LIT-12011252)* for detailed requirements and procedures for installing and operating UUKL/UUKLC 864 Listed Metasys system devices. Failure to meet the requirements or follow the procedures in the *Metasys System UL 864 Ninth Edition UUKL/UUKL7 Smoke Control System Technical Bulletin (LIT-12011252)* can void the UUKL/UUKLC 864 listing for Smoke Control Equipment.

**Note:** At CCT Release 10.1, a new capability was introduced allowing VMAs, FECs, and FACs to communicate by using either the BACnet or the N2 field bus networking protocol. The operation of the IOM Input/Output Module is not affected by the selection of the BACnet or the N2 protocol in the host controller.

## North American Emissions Compliance

### Canada

This Class (A) digital apparatus meets all the requirements of the Canadian Interference-Causing Equipment Regulations.

Cet appareil numérique de la Classe (A) respecte toutes les exigences du Règlement sur le matériel brouilleur du Canada.

### United States

This equipment has been tested and found to comply with the limits for a Class A digital device pursuant to Part 15 of the FCC Rules. These limits are designed to provide reasonable protection against harmful interference when this equipment is operated in a commercial environment. This equipment generates, uses, and can radiate radio frequency energy and, if not installed and used in accordance with the instruction manual, may cause harmful interference to radio communications. Operation of this equipment in a residential area may cause harmful interference, in which case the users will be required to correct the interference at their own expense.

## Installation

Observe these guidelines when installing a field controller:

- Transport the controller in the original container to minimize vibration and shock damage.
- Verify that all parts shipped with the controller.
- Do not drop the controller or subject it to physical shock.

### Parts Included

- one controller with removable terminal blocks (Power and SA/FC bus are removable)
- one installation instructions sheet

**Figure 1: Controller Mounting Positions**

## Materials and Special Tools Needed

- three fasteners appropriate for the mounting surface (M4 screws or #8 screws)
- one 20 cm (8 in.) or longer piece of 35 mm DIN rail and appropriate hardware for DIN rail mount (only)
- small straight-blade screwdriver for securing wires in the terminal blocks

## Mounting

Observe these guidelines when mounting a field controller:

- Ensure the mounting surface can support the controller, DIN rail, and any user-supplied enclosure.
- Mount the controller horizontally on 35 mm DIN rail whenever possible.
- Mount the controller in the proper mounting position.
- Mount the controller on a hard, even surface whenever possible in wall-mount applications.
- Use shims or washers to mount the controller securely and evenly on the mounting surface.
- Mount the controller in an area free of corrosive vapors and observe the Ambient Conditions requirements in .
- Provide for sufficient space around the controller for cable and wire connections for easy cover removal and good ventilation through the controller (50 mm [2 in.] minimum on the top, bottom, and front of the controller).
- Do not mount the controller on surfaces prone to vibration, such as duct work.
- Do not mount the controller in areas where electromagnetic emissions from other devices or wiring can interfere with controller communication.

Observe these additional guidelines when mounting a field controller in a panel or enclosure:

- Mount the controller so that the enclosure walls do not obstruct cover removal or ventilation through the controller.
- Mount the controller so that the power transformer and other devices do not radiate excessive heat to the controller.
- Do not install the controller in an airtight enclosure.

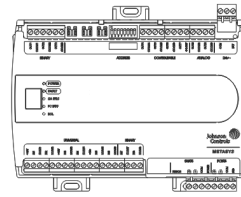

**Horizontal Mount Position**  
Preferred for Wall Mounting  
Required for DIN Rail Mounting

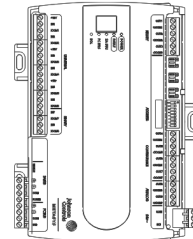

**Vertical Mount Position**  
Acceptable for Wall Mounting

FIG.rec\_mounting\_positions

## DIN Rail Mount Applications

Mounting the controller horizontal on 35 mm DIN rail is the preferred mounting method.

To mount a field controller on 35 mm DIN rail:

1. Securely mount a 20 cm (8 in.) or longer section of 35 mm DIN rail horizontal and centered in the desired space so that the controller mounts in the horizontal position shown in .
2. Pull the bottom mounting clip outward from the controller to the extended position as shown in .
3. Hang the controller on the DIN rail by the hooks at the top of the (DIN rail) channel on the back of the controller ( ), and position the controller snugly against the DIN rail.
4. Push the bottom mounting clip inward (up) to secure the controller on the DIN rail.

To remove the controller from the DIN rail, pull the bottom mounting clip out to the extended position and carefully lift the controller off the DIN rail.

## Wall Mount Applications

To mount a field controller directly on a wall or other flat vertical surface:

1. Pull the bottom mounting clip outward and ensure it is locked in the extended position as shown in .
2. Position the controller in a proper mounting position shown in and mark the mounting hole locations on the wall or surface using the dimensions shown in . Or, hold the controller up to the wall or surface in a proper mounting position and mark the hole locations through the mounting clips.
3. Drill holes in the wall or surface at the marked locations, and insert appropriate wall anchors in the holes (if necessary).

4. Hold the controller in place, and insert the screws through the mounting clips and into the holes (or wall anchors). Carefully tighten all of the screws.

**Important:** Do not overtighten the mounting screws. Overtightening the screws may damage the mounting clips.

**Figure 2: Back of IOM17 or IOM27 Controller Showing Extended Mounting Clips, DIN Rail Channel, and Mounting Dimensions, mm (in.)**

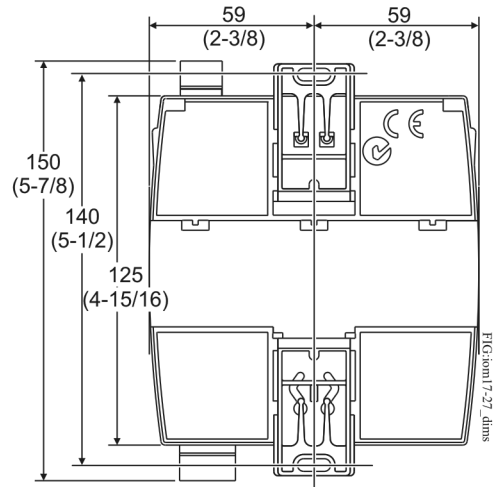

**Figure 3: IOM17 and IOM27 Physical Features**

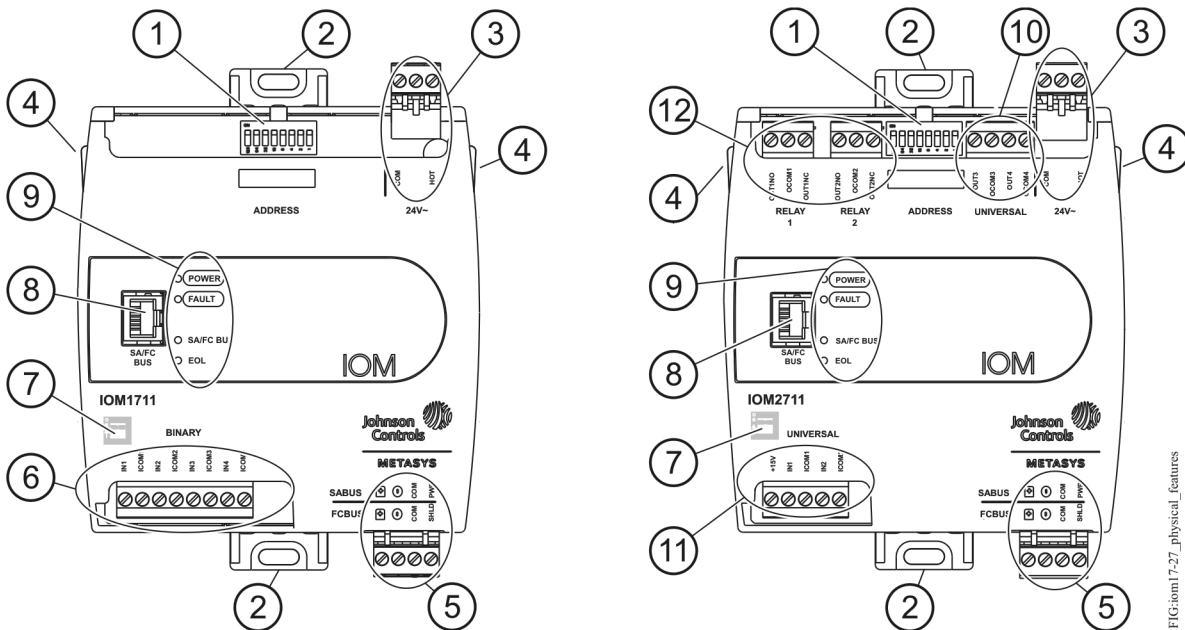

FIG:iomi17-27\_physical\_features

**Table 1: IOM17 and IOM27 Physical Features**

Callout	Physical Feature: Description and References
1	Device Address DIP Switch Block. See <a href="#">Setting the Device Addresses</a> for more information.
2	Mounting Clip (One of Two).
3	24 VAC, Class 2 Supply Power Terminal Block. See <a href="#">Table 5</a> for more information.
4	Cover Lift Tab (One of Two). See <a href="#">Removing the Controller Cover</a> for more information.
5	Sensor Actuator (SA) Bus / Field Controller (FC) Bus Terminal Block. See <a href="#">Table 5</a> for more information.
6	Binary Inputs (BIs) Terminal Block (Not available on IOM27). See <a href="#">Table 3</a> for more information.
7	End-of-Line (EOL) Switch. See <a href="#">Setting the End-of-Line (EOL) Switch</a> for more information. <b>Note:</b> The EOL Switch is located under the controller cover. You must remove the cover to change the EOL switch position.
8	Sensor Actuator (SA) Bus or Field Controller (FC) Bus Port (RJ-12 6-pin Modular Jack). See <a href="#">Table 5</a> for more information.
9	Light-Emitting Diode (LED) Status Indicators. See <a href="#">Table 7</a> for more information.
10	Universal Outputs (UO) Terminal Blocks (Not available on IOM17). See <a href="#">Table 3</a> for more information.
11	Universal Inputs (UI) Terminal Blocks (Not available on IOM17). See <a href="#">Table 3</a> for more information.
12	Relay Output Terminal Blocks (Not available on IOM17). See <a href="#">Table 3</a> for more information.



**Figure 5: SA Bus Terminal Block Wiring**

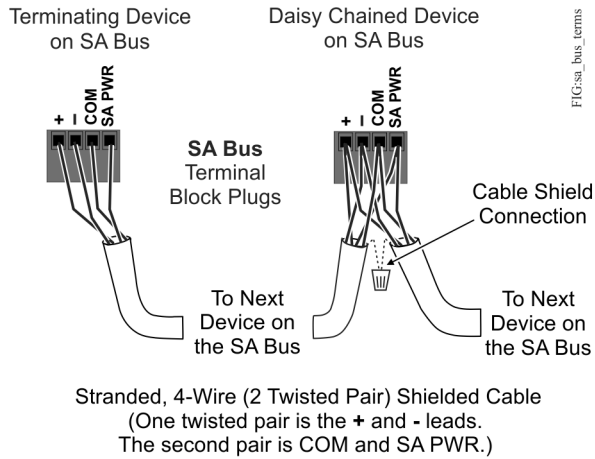

**Note:** The SA PWR/SHLD terminal does not supply 15 VDC. The SA PWR/SHLD terminal is isolated and can be used to connect (daisy chain) the 15 VDC power leads on the SA bus ( ) or the cable shields on the FC bus ( ). The SA bus supervisor (FAC, FEC, or VMA) supplies 15 VDC to devices on the SA Bus requiring power.

**SA/FC Bus Port**

The SA/FC bus port on the front of the controller is an RJ-12, 6-position modular jack that provides a connection for devices on the SA bus, a Wireless Commissioning Converter, ZigBee® wireless dongle, or a ZFR1811 Wireless Router (depending on which bus the IOM is operating on).

The SA/FC bus port is connected internally to the SA/FC bus terminal block. See [Table 5](#) for more information. The SA/FC Bus Port pin assignment is shown in the Pin Number Assignments figure below.

**Figure 6: Pin Number Assignments for Sensor, SA Bus and FC Bus Ports on Controllers**

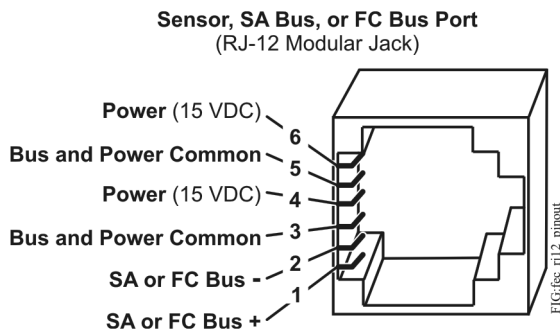

**Supply Power Terminal Block**

The 24 VAC supply power terminal block is a gray, removable, 3-terminal plug that fits into a board-mounted jack on the top right of the controller.

**Note:** If CE compliance is required for the MS-IOM1711-0 or MS-IOM2711-2 product and application, the ferrite ring that is included in the package shall be used in the installation. Use of the ferrite ring ensures compliance to the EMC Directive in all possible applications. The ferrite ring does not affect UL864 Smoke Control applications. It is not required for applications in North America.

To install the ferrite ring, pass the two 24 VAC supply power wires through the opening of the ring and then complete five wraps or turns of both wires around the outside of the ring and back through the center opening as shown in the following figure. Locate the ferrite ring as near to the supply power terminal plug as possible while still allowing for a typical connection to the controller with the terminal plug.

**Figure 7: Wrapped Ferrite Ring**

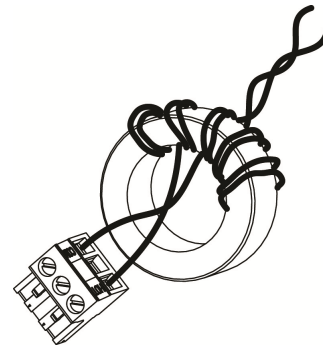

Wire the 24 VAC supply power wires from the transformer to the HOT and COM terminals on the terminal plug as shown in the following figure. The middle terminal on the supply power terminal block is not used. See [Table 5](#) for more information about the Supply Terminal Block.

**Figure 8: 24 VAC Supply Power Terminal Block Wiring**

Disconnect supply power to controller by unplugging Supply Power Plug from Supply Power Jack.

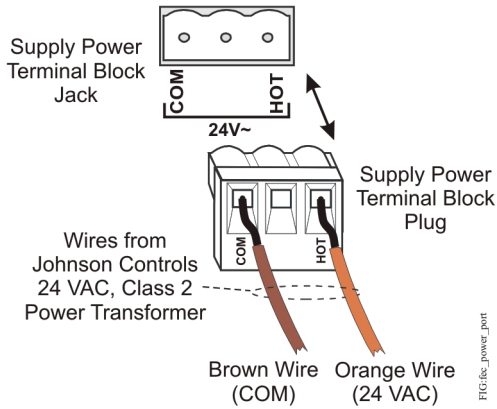

**Note:** The supply power wire colors may be different on transformers from other manufacturers. Refer to the transformer manufacturer's instructions and the project installation drawings for wiring details.

**Important:** Connect 24 VAC supply power to the controller and all other network devices so that transformer phasing is uniform across the network devices. Powering network devices with uniform 24 VAC supply power phasing reduces noise, interference, and ground loop problems. The controller does not require an earth ground connection.

## Termination Details

A set of Johnson Controls® termination diagrams provides details for wiring inputs and outputs to the controllers. See the figures in this section for the applicable termination diagrams.

## Wireless Network Applications

The controller can also be installed in a wireless application using a ZFR1811 Wireless Field Bus Router.

To configure a controller for use with the ZFR1811 Series Wireless Field Bus system:

**Note:** IOMs can talk wirelessly on an FC bus only.

1. Connect the ZFR1811 Wireless Field Bus Router to the FC bus port (RJ-12 modular jack) on the front of the controller.
2. Ensure that the controller's device address DIP switches are set to the correct device address. See [Setting the Device Addresses](#).
3. Set DIP switch 128 to ON, which enables wireless operation on the controller.

For more information on installing a controller in a wireless configuration, refer to the *ZFR1811 Wireless Field Bus Router Installation Instructions (Part No. 24-10325-1)*.

**Table 2: Termination Details**

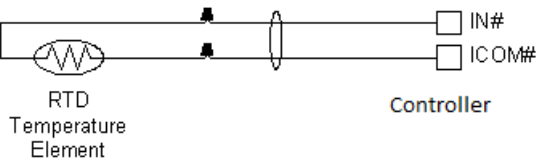
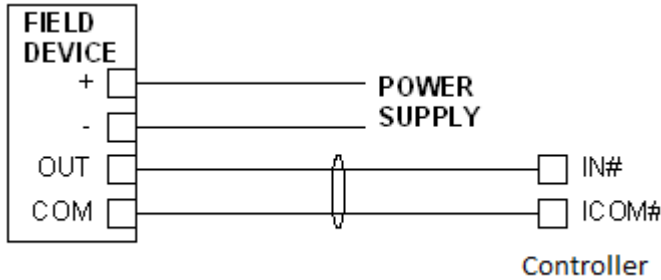
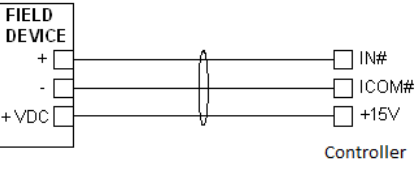
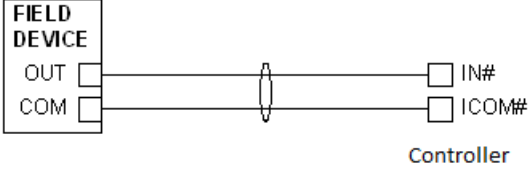
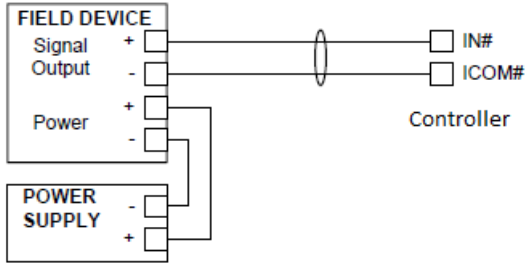
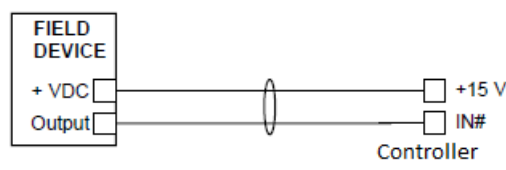
Type of Field Device	Type of Input/Output	Termination Diagrams
Temperature Sensor	UI	 <p>RTD Temperature Element</p> <p>Controller</p>
Voltage Input - External Source	UI	 <p>FIELD DEVICE</p> <p>+</p> <p>-</p> <p>OUT</p> <p>COM</p> <p>POWER SUPPLY</p> <p>Controller</p>
Voltage Input - Internal Source	UI	 <p>FIELD DEVICE</p> <p>+</p> <p>-</p> <p>+VDC</p> <p>Controller</p>
Voltage Input (Self-Powered)	UI	 <p>FIELD DEVICE</p> <p>OUT</p> <p>COM</p> <p>Controller</p>
Current Input - External Source (Isolated)	UI	 <p>FIELD DEVICE</p> <p>Signal +</p> <p>Signal Output -</p> <p>Power +</p> <p>Power -</p> <p>POWER SUPPLY</p> <p>-</p> <p>+</p> <p>Controller</p>
Current Input - Internal Source (2 wire)	UI	 <p>FIELD DEVICE</p> <p>+VDC</p> <p>Output</p> <p>Controller</p>

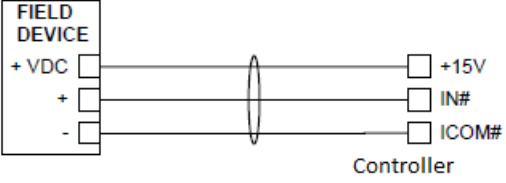
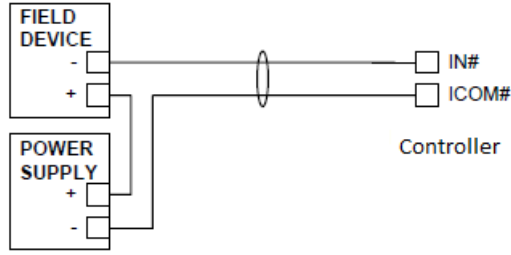
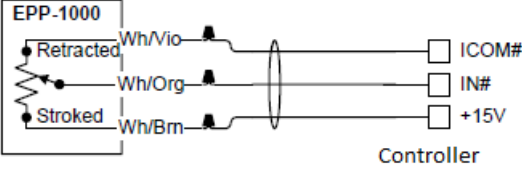
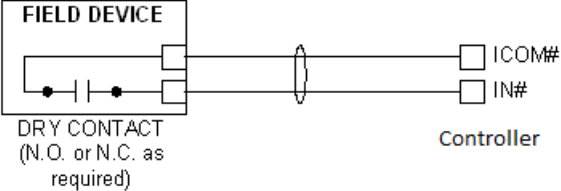
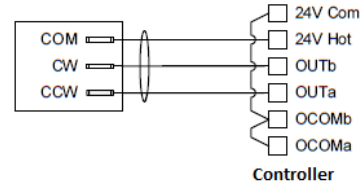
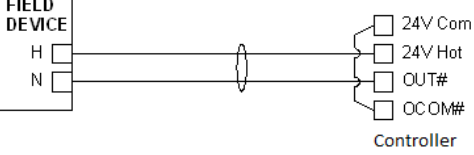
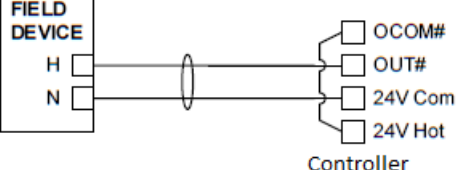

**Table 2: Termination Details**

Type of Field Device	Type of Input/Output	Termination Diagrams
Current Input - Internal Source (3 wire)	UI	
Current Input - External Source (in Loop)	UI	
Feedback from EPP-1000	UI	
Dry Contact	UI or BI	 <p>DRY CONTACT (N.O. or N.C. as required)</p>
	UO	
24 VAC Binary Output (Switch Low, Externally Sourced)	UO	
24 VAC Binary Output (Switch High, Externally Sourced)	UO	

**Table 2: Termination Details**

Type of Field Device	Type of Input/Output	Termination Diagrams
Incremental Control to Actuator (Switch High, Externally Sourced)	UO	<p>COM → 24V Com          CW → 24V Hot          CCW → OUTb          → OUTa          → OCOMb          → OCOMa          Controller</p>
Analog Output (Current)	UO	<p>FIELD DEVICE          + → OUT#          - → OCOM#          Controller</p>
4–20 mA Output to Actuator	UO	<p>Common 1          Power 2          Calibration Output 3          Current Input 4          Voltage Input 5          Feedback 6          Terminal Block 1</p> <p>Add Jumper from 24VAC Com to only one AO Com per Transformer</p> <p>24VAC Com          24VAC Hot          OCOM#          OUT#          Controller</p>
Voltage (Analog Output)	UO	<p>FIELD DEVICE          + → OUT#          - → OCOM#          Controller</p>
4–20 mA Output to Actuator	UO	<p>Common 1          Power 2          Calibration Output 3          Current Input 4          Voltage Input 5          Feedback 6          Terminal Block 1</p> <p>N          H          24 VAC</p> <p>OCOM#          OUT#          Controller</p>
0–20 VDC Output to Actuator (External Source)	UO	<p>Common 1          Power 2          Calibration Output 3          Current Input 4          Voltage Input 5          Feedback 6          Terminal Block 1</p> <p>Add Jumper from 24VAC Com to only one AO Com per Transformer</p> <p>24VAC Com          24VAC Hot          OCOM#          OUT#          Controller</p>

**Table 2: Termination Details**

Type of Field Device	Type of Input/Output	Termination Diagrams
0–10 VDC Output to Actuator (Internal Source)	UO	
24 VAC Binary Output (Switch Low, Externally Sourced)	RO	
24 VAC Binary Output (Switch High, Externally Sourced)	RO	

## Terminal Wiring Guidelines, Functions, Ratings, and Requirements

### Input and Output Wiring Guidelines

Table 3 provides information and guidelines about the functions, ratings, and requirements for the controller input and output terminals; and references guidelines for determining proper wire sizes and cable lengths.

In addition to the wiring guidelines in Table 3, observe these guidelines when wiring controller inputs and outputs:

- Run **all** low-voltage wiring and cables separate from high-voltage wiring.
- All input and output cables, regardless of wire size or number of wires, should consist of stranded, insulated, and twisted copper wires.
- Shielded cable is not required for input or output cables.
- Shielded cable is recommended for input and output cables that are exposed to high electromagnetic or radio frequency noise.
- Inputs/outputs with cables less than 30 m (100 ft) typically do not require an offset in the software setup. Cable runs over 30 m (100 ft) may require an offset in the input/output software setup.

**Table 3: IOM17 and IOM27 Terminal Blocks, Functions, Ratings, Requirements, and Cables**

Terminal Block Label	Terminal Label	Function, Ratings, Requirements	Determine Wire Size and Maximum Cable Length
<b>UNIVERSAL</b> (Inputs) (IOM27)	<b>+15 V</b>	<b>15 VDC Power Source</b> for active (3-wire) input devices connected to the Universal IN <sub>n</sub> terminals.  Provides 35 mA total current	Same as (Universal) IN <sub>n</sub>  <b>Note:</b> Use 3-wire cable for devices that source power from the +15V terminal.
	IN <sub>n</sub>	<b>Analog Input - Voltage Mode (0–10 VDC)</b>  10 VDC maximum input voltage  Internal 75k ohm Pull-down	See Guideline A in <a href="#">Table 4</a> .
		<b>Analog Input - Current Mode (4–20 mA)</b>  Internal 100 ohm load impedance	See Guideline B in <a href="#">Table 4</a> .
		<b>Analog Input - Resistive Mode (0–600k ohm)</b>  Internal 12 V, 15k ohm pull up  Qualified Sensors: 0-2k ohm potentiometer, RTD (1k Nickel [Johnson Controls® sensor], 1k Platinum, and A99B Silicon Temperature Sensor) Negative Temperature Coefficient (NTC) Sensor (10k Type L, 10k JCI Type II, 2.252k Type II)	See Guideline A in <a href="#">Table 4</a> .
		<b>Binary Input - Dry Contact Maintained Mode</b>  1 second minimum pulse width  Internal 12 V, 15k ohm pull up	See Guideline A in <a href="#">Table 4</a> .
	ICOM <sub>n</sub>	<b>Universal Input Common</b> for all Universal Input terminals  <b>Note:</b> All Universal ICOM <sub>n</sub> terminals share a common, which is isolated from all other commons.	Same as (Universal) IN <sub>n</sub>
<b>BINARY</b> (Inputs) (IOM17)	IN <sub>n</sub>	<b>Binary Input - Dry Contact Maintained Mode</b>  0.01 second minimum pulse width  Internal 18 V, 3k ohm pull up	See Guideline A in <a href="#">Table 4</a> .
		<b>Binary Input - Pulse Counter/Accumulator Mode</b>  0.01 second minimum pulse width (50 Hz at 50% duty cycle)  Internal 18 V, 3k ohm pull up	
	ICOM <sub>n</sub>	<b>Binary Input Common</b> for all Binary Input (IN) terminals  <b>Note:</b> All Binary ICOM <sub>n</sub> terminals share a common, which is isolated from all other commons.	

**Table 3: IOM17 and IOM27 Terminal Blocks, Functions, Ratings, Requirements, and Cables**

Terminal Block Label	Terminal Label	Function, Ratings, Requirements	Determine Wire Size and Maximum Cable Length
<b>Universal</b> (Outputs) (IOM27)	OUT <sub>n</sub>	<b>Analog Output - Voltage Mode (0–10 VDC)</b> 10 VDC maximum output voltage 10 mA maximum output current Required an external load of 1,000 ohm or more. <b>Note:</b> The Analog Output (AO) operates in the Voltage Mode when connected to devices with impedances greater than 1,000 ohm. Devices that drop below 1,000 ohm may not operate as intended for Voltage Mode applications.	See Guideline <b>A</b> in <a href="#">Table 4</a> .
		<b>Analog Output - Current Mode (4–20 mA)</b> Requires and external load between 0 and 300 ohm. <b>Note:</b> The Analog Output (AO) operates in the Current Mode when connected to devices with impedances less than 300 ohm. Devices that exceed 300 ohm may not operate as intended for Current Mode applications.	See Guideline <b>B</b> in <a href="#">Table 4</a> .
		<b>Binary Output Mode - 24 VAC/DC Field-effect Transistor (FET)</b> Connects OUT <sub>n</sub> to OCOM <sub>n</sub> when activated. 30 VAC maximum output voltage 0.5 A maximum output current 1.3 A at 25% duty cycle 40 mA minimum load current (hold current)	See Guideline <b>B</b> in <a href="#">Table 4</a> .
	OCOM <sub>n</sub>	<b>Universal Output (UO) Common</b> Isolated from all other terminal commons, including other UO Commons.	Same as OUT

**Table 3: IOM17 and IOM27 Terminal Blocks, Functions, Ratings, Requirements, and Cables**

Terminal Block Label	Terminal Label	Function, Ratings, Requirements	Determine Wire Size and Maximum Cable Length
<b>RELAY</b> <i>n</i> (Outputs) (IOM27)	<b>OUT NO<sub>n</sub></b>	<b>Normal Open Contact</b> Connects OCOM to OUT NO when activated. <b>UL Listed</b> (-0 model only) 1/4 hp 120 VAC, 1/2 hp 240 VAC 360 VA Pilot Duty at 120/240 VAC (B300) 3 A Non-inductive 24-240 VAC <b>CE Marking</b> (-2 model only): 6 (4) A N.O. or N.C. only, 240 VAC	The Relay output terminals can accommodate the following maximum wire sizes:  Two wires per terminal: 1.5 mm <sup>2</sup> (16 AWG) maximum wire size <b>or</b> One wire per terminal: 2.5 mm <sup>2</sup> (12 AWG) maximum  <b>Note:</b> You must determine the <b>required</b> wire size for the high-voltage (>30V) terminals according to relay ratings, the applied load, and the local, national, or regional electrical codes.
	<b>OCOM<sub>n</sub></b>	<b>Relay Common</b> Isolated from all other terminal commons, including other Relay Commons.	
	<b>OUT NC<sub>n</sub></b>	<b>Normal Closed Contact</b> Connects OCOM to OUT NC when activated. <b>UL Listed</b> (-0 model only) 1/4 hp 120 VAC, 1/2 hp 240 VAC 360 VA Pilot Duty at 120/240 VAC (B300) 3 A Non-inductive 24-240 VAC <b>CE Marking</b> (-2 model only): 6 (4) A N.O. or N.C. only, 240 VAC	

## Cable and Wire Length Guidelines

[Table 4](#) defines cable length guidelines for the various wire sizes that may be used for wiring low-voltage (<30V) input and outputs.

**Table 4: Cable Length Guidelines and Recommended Wire Sizes for Low-Voltage (<30V) Inputs and Outputs**

Guideline <sup>1</sup>	Wire Size/Gauge and Type	Maximum Cable Length and Type	Assumptions
<b>A</b>	1.5 mm <sup>2</sup> (18 AWG) stranded copper	457 m (1,500 ft) twisted wire	100 mV maximum voltage drop Depending on cable and the connected input or output device, you may have to define an offset in the setup software for the input or output point.
	0.8 mm (20 AWG) stranded copper	297 m (975 ft) twisted wire	
	0.6 mm (22 AWG) stranded copper	183 m (600 ft) twisted wire	
	N/A (24 AWG) stranded copper	107 m (350 ft) twisted wire	
<b>B</b>	1.5 mm <sup>2</sup> (18 AWG) stranded copper	229 m (750 ft) twisted wire	100 mV maximum voltage drop Depending on cable and the connected input or output device, you may have to define an offset in the setup software for the input or output point.
	0.8 mm (20 AWG) stranded copper	137 m (450 ft) twisted wire	
	0.6 mm (22 AWG) stranded copper	91 m (300 ft) twisted wire	
	N/A (24 AWG) stranded copper	61 m (200 ft) twisted wire	
<b>C</b>	See <a href="#">Figure 9</a> to select wire size/gauge. Use stranded copper wire	See <a href="#">Figure 9</a> to determine cable length. Use twisted wire cable.	N/A

<sup>1</sup> The required wire sizes and lengths for high-voltage (>30V) Relay Outputs are determined by the load connected to the relay and local, national, or regional electrical codes.

## Maximum Cable Length versus Load Current

Use [Figure 9](#) to estimate the maximum cable length relative to the wire size and the load current (in mA) when wiring inputs and outputs.

**Note:** [Figure 9](#) applies to low-voltage (<30V) inputs and outputs only. The required wire size and length for high-voltage (>30V) Relay Outputs is determined by the load connected to the relay and local electrical codes.

**Figure 9: Maximum Wire Length for Low-Voltage (<30V) Inputs and Outputs by Current and Wire Size**

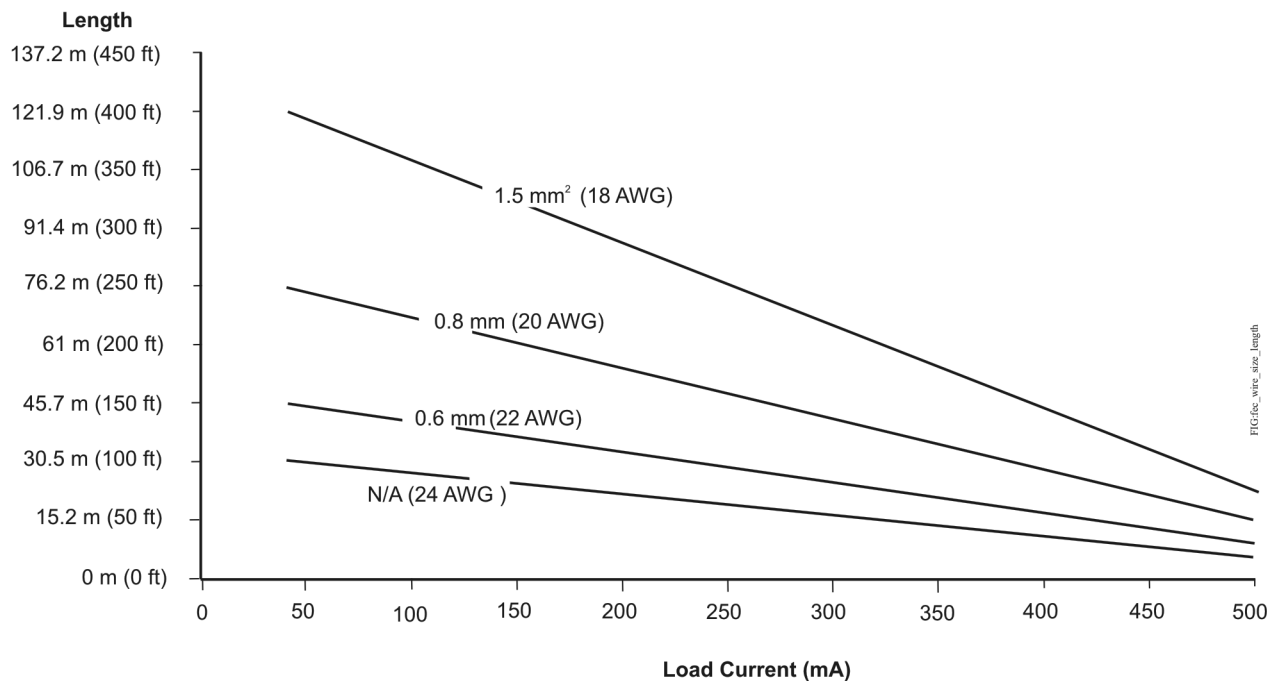

## SA/FC Bus and Supply Power Wiring Guidelines

[Table 5](#) provides information about the functions, ratings, and requirements for the communication bus and supply power terminals; and guidelines for wire sizes, cable types, and cable lengths when wiring the controller's communication buses and supply power.

In addition to the guidelines in [Table 5](#), observe these guidelines when wiring an SA or FC bus and the 24 VAC supply power:

- Run **all** low-voltage wiring and cables separate from high-voltage wiring.
- All SA and FC bus cables, regardless of wire size, should be twisted, insulated, stranded copper wire.
- Shielded cable is strongly recommended for all SA and FC bus cables.
- Refer to the *MS/TP Communications Bus Technical Bulletin (LIT-12011034)* for detailed information regarding wire size and cable length requirements for the SA and FC buses.

**Table 5: Communications Bus and Supply Power Terminal Blocks, Functions, Ratings, Requirements, and Cables**

Terminal Block/Port Label	Terminal Labels	Function, Electrical Ratings/Requirements	Recommended Cable Type <sup>1</sup>
FCBUS <sup>2</sup> or SABUS <sup>2</sup>	+ -	FC or SA Bus Communications	FC Bus: 0.6 mm (22 AWG) stranded, 3-wire twisted, shielded cable recommended.
	COM	Signal Reference (Common) for FC or SA bus communications	SA Bus: 0.6 mm (22 AWG) stranded, 4-wire (2 twisted-pairs), shielded cable recommended.
	SHLD or SAPWR	<b>SHLD on FC Bus:</b> Isolated terminal (optional shield drain connection) <b>SAP WR on SA Bus:</b> 15 VDC power lead connection <b>Note:</b> The SA PWR terminal on an IOM controller does not supply 15 VDC. The SA bus supervisor supplies 15 VDC to devices on the SA Bus requiring power.	<b>Note:</b> On the SA Bus, the + and - wire are one twisted pair, and the COM and SA PWR are the second twisted pair of wires.
SA/FC BUS <sup>2</sup> (Port)		RJ-12 6-Position Modular Connector provides: FC or SA Bus Communications FC or SA Bus Signal Reference and 15 VDC Common Commissioning Converter or ZFR1811 Wireless Router (Maximum total current draw for SA Bus is 240 mA.)	Wireless Commissioning Converter retractable cable or 24 AWG 3-pair CAT 3 Cable <30.5 m (100 ft)
24~	HOT	<b>24 VAC Power Supply - Hot</b> Supplies 20-30 VAC (Nominal 24 VAC)	0.8 mm to 1.5 mm <sup>2</sup> (18 AWG) 2-wire
	COM	<b>24 VAC Power Supply - Common</b> (Isolated from all other Common terminals on controller.)	

<sup>1</sup> See [Table 4](#) to determine wire size and cable lengths for cables.

<sup>2</sup> The SA Bus and FC Bus wiring recommendations in this table are for MS/TP bus communications at 38,400 baud. For more information, refer to the *MS/TP Communications Bus Technical Bulletin (LIT-12011034)*.



# Setup and Adjustments

## Setting the Device Addresses

Metasys® field controllers are master devices on MS/TP (SA or FC) buses. Before operating controllers on a bus, you **must** set a valid and unique device address for each controller on the bus. You set a controller's device address by setting the positions of the switches on the DIP switch block at the top of the controller (*Figure 10*). Device addresses 4 through 127 are the valid addresses for these controllers.

The DIP switch block has eight switches numbered 128, 64, 32, 16, 8, 4, 2, and 1. Switches 64 through 1 are device address switches. Switch 128 is a mode switch that enables a controller to operate on a ZFR1800 Series Wireless Field Bus. Switch 128 must be set to Off for all hard-wired SA and FC bus applications. Set switch 128 to ON for wireless FC bus applications **only**.

**Figure 10: Device Address DIP Switch Block Set to Address 21**



**Note:** Switch 128 is used to enable or disable a controller for wireless operation.

**Note:** Metasys field controllers ship with switch 128 ON and the remaining address switches off rendering the controllers wired slave devices, which do not operate on MS/TP buses, but will not interfere with bus operation. Set a valid and unique device address on the controller before applying power to the controller on the bus.

To set the device addresses on Metasys field controllers:

1. Set **all** of the switches on the address DIP switch block (128 through 1) to Off.
2. Set one or more of the seven address switches (64 through 1) to ON, so that the sum of the switch numbers set to ON equals the intended device address. See *Table 6* for valid device addresses.

Set the highest number switch that is less than or equal to the intended device address to ON. Then continue setting lower numbered switches until the total equals the intended address. For example, if the intended device address is 21, set switch 16 to ON first, then set switch 4 ON, followed by switch 1 (16+4+1= 21).

3. Set switch 128 to ON **only** for controllers on a ZFR1800 Series Wireless Field Bus application. For all hard-wired SA and FC bus applications, ensure that switch 128 is set to Off.

**Note:** Do **not** connect a controller with switch 128 set to ON to an active (hard-wired) SA or FC bus. When a controller with switch 128 set to ON and a device address from 4 to 127 is connected to a wired field bus, the entire field bus is rendered inoperable until the controller is disconnected or switch 128 is set to Off.

Refer to the *ZFR1800 Series Wireless Field Bus System Technical Bulletin (LIT-12011295)* for more information on device addresses in wireless applications.

4. Set a unique and sequential device address for each of the controllers connected on the SA or FC bus starting with device address 4.

To ensure the best bus performance, set sequential device addresses with no gaps in the device address range (4, 5, 6, 7, 8, 9, and so on). The controllers do **not** need to be physically connected on the bus in their numerical device address order.

5. Write each controller's device address on the white label below the DIP switch block on the controller's cover.

*Table 6* describes the FC bus and SA bus device addresses for Johnson Controls® MS/TP communications bus applications.

Refer to the *MS/TP Communications Bus Technical Bulletin (LIT-12011034)* for more information on controller device addresses and how to set them on MS/TP buses.

**Table 6: SA/FC Bus Device Address Descriptions**

Device Address	Use on Description
0 (Switch 128 Off)	Reserved for FC Bus Supervisory Controller (not for use on controllers).
1 to 3 (Switch 128 Off)	Reserved for peripheral devices (not for use on controllers).
4 to 127 (Switch 128 Off)	Used for MS/TP master devices (controllers) that are hardwired to an SA Bus or FC Bus.

**Table 6: SA/FC Bus Device Address Descriptions**

Device Address	Use on Description
0 to 3 (Switch 128 ON)	Reserved addresses for wired slave devices (not for use on controllers). <b>Note:</b> Metasys controllers ship with switch 128 ON and the remaining address switches off rendering the controllers wired slave devices, which do not operate on MS/TP buses.
4 to 127 (Switch 128 ON)	Valid for MS/TP Master controllers on <b>wireless FC Buses only</b> . <b>Note:</b> Do <b>not</b> connect a controller with switch 128 ON to an active ( <b>hard-wired</b> ) SA or FC bus. When a controller with switch 128 ON and a device address from 4 to 127 is connected to a wired field bus, the entire field bus is rendered inoperable until the controller is disconnected or switch 128 is set to Off.

## Removing the Controller Cover

**Important:** Electrostatic discharge can damage controller components. Use proper electrostatic discharge precautions during installation, setup, and servicing to avoid damaging the controller.

**Important:** Disconnect all power sources to the controller before removing cover and changing the position of any jumper or the EOL switch on the controller. Failure to disconnect power before changing a jumper or EOL switch position can result in damage to the controller and void any warranties.

The controller cover is held in place by four plastic latches that extend from the base and snap into slots on the inside of the housing cover.

To remove the controller cover:

- Place your fingernails under the two cover lift tabs ([Figure 3](#)) on the sides of the housing cover and gently pry the top of the cover away from the base to release the cover from the two upper latches.
- Pivot the top of the cover further to release it from the lower two latches.
- Replace the cover by placing it squarely over the base, and then gently and evenly push the cover on to the latches until they snap into the latched position.

**Figure 11: IOM17 or IOM27 with Cover Removed Showing EOL Switch Location**

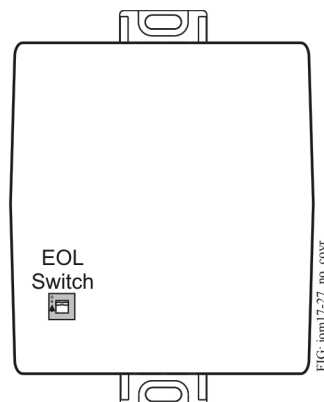

## Setting the End-of-Line (EOL) Switch

Each controller has an EOL switch, which, when set to ON, sets the controller as a terminating device on the bus. See [Figure 11](#) for the EOL switch location. The default EOL switch position is Off.

**Figure 12: End-of-Line Switch Positions**



To set the EOL switch on a controller:

- Determine the physical location of the controller on the SA or FC bus.
- Determine if the controller must be set as a terminating device on the bus.  
**Note:** The EOL termination rules for SA buses and FC buses are different. Refer to the *MS/TP Communications Bus Technical Bulletin (LIT-12011034)* for detailed information regarding EOL termination rules and EOL switch settings on SA and FC buses.
- If the controller is a terminating device on the FC bus, set the EOL switch to ON. If the controller is not a terminating device on the bus, set the EOL switch to Off.

When a controller is connected to power with its EOL switch set to ON, the amber EOL LED on the controller cover is lit.

## Commissioning the Controllers

You commission controllers with the Controller Configuration Tool (CCT) software, either via a Wireless Commissioning Converter, a ZigBee wireless dongle, or in BACnet® router mode when connected to an NAE or NCE. Refer to the Controller Tool *Help (LIT-12011147)* for detailed information on commissioning controllers.

## Troubleshooting the Controllers

Observe the Status LEDs on the front of the controller and see [Table 7](#) to troubleshoot the controller.

**Table 7: Status LEDs and Descriptions of LED States**

LED Label	LED Color	Normal LED State	Description of LED States
POWER	Green	On Steady	Off Steady = No Supply Power or the controller's polyswitch/resettable fuse is open. Check Output wiring for short circuits and cycle power to controller. On Steady = Power Connected
FAULT	Red	Off Steady	Off Steady = No Faults On Steady = Device Fault; no application loaded; Main Code download required, if controller is in Boot mode, or a firmware mismatch exists between the controller and the ZFR1811 Wireless Field Bus Router. Blink - 2 Hz = Download or Startup in progress, not ready for normal operation
SA/FC BUS	Green	Blink - 2 Hz	Blink - 2 Hz = Data Transmission (normal communication) Off Steady = No Data Transmission (N/A - auto baud not supported) On Steady = Communication lost, waiting to join communication ring
EOL	Amber	Off (Except on terminating devices)	On Steady = EOL switch in ON position Off Steady = EOL switch in Off position

## Repair Information

If a controller fails to operate within its specifications, replace the controller. For a replacement controller, contact your Johnson Controls® representative.

## Accessories

See [Table 8](#) for controller accessories ordering information.

**Table 8: Accessories Ordering Information**

Product Code Number	Description
MS-BTCVT-1	Bluetooth® Wireless Commissioning Converter
MS-ZFR1811-0	Wireless Field Bus Router
TP-2420	Transformer, 120 VAC Primary to 24 VAC secondary, 20 VA, Wall Plug
Y65T31-0	Transformer, 120/208/240 VAC Primary to 24 VAC Secondary, 40 VA, Foot Mount, 8 in. Primary Leads and Secondary Screw Terminals, Class 2 <b>Note:</b> Additional Y6x-x Series transformers are also available. Refer to the <i>Series Y63, Y64, Y65, Y66, and Y69 Transformers Product Bulletin (LIT-125755)</i> for more information.
AS-XFR050-0	Power transformer (Class 2, 24 VAC, 50 VA maximum output), no enclosure
MS-TBK4BUS-0	Replacement SA/FC Bus Terminal Blocks, 4-Position, Gray, Bulk Pack <b>Note:</b> This is the standard terminal block that is provided with the controller.
AP-TBK4SA-0	Replacement SA Bus Terminal Blocks, 4-Position, Brown, Bulk Pack of 10 <b>Note:</b> These terminal blocks can be used as replacement parts if keeping consistent terminal block colors is important.

**Table 8: Accessories Ordering Information**

Product Code Number	Description
AP-TBK4FC-0	Replacement FC Bus Terminal Blocks, 4-Position, Blue, Bulk Pack of 10 <b>Note:</b> These terminal blocks can be used as replacement parts if keeping consistent terminal block colors is important.
AP-TBK3PW-0	Replacement Power Terminal Blocks, 3-Position, Brown, Bulk Pack of 10
ZFR-USBHA-0	USB Dongle with ZigBee Driver provides a wireless connection through CCT to allow wireless commissioning of the wirelessly enabled FEC, FAC, IOM, and VMA16 field controllers. Also allows use of the ZFR Checkout Tool (ZCT) in CCT. <b>Note:</b> The ZFR-USBHA-0 replaces the IA OEM DAUBI_2400 ZigBee USB dongle. For additional information on the ZFR-USBHA-0 ZigBee dongle, refer to the <i>ZFR1800 Series Wireless Field Bus System Technical Bulletin (LIT-12011295)</i> or <i>ZFR1800 Series Wireless Field Bus System Quick Reference Guide (LIT-12011630)</i> .

## Technical Specifications

**Table 9: IOM1711 and IOM2711 Technical Specifications**

Product Code Numbers	MS-IOM1711 Series Input/Output Module MS-IOM2711 Series Input/Output Module
Supply Voltage	24 VAC (nominal, 20 VAC minimum/30 VAC maximum), 50/60 Hz, power supply Class 2 (North America), Safety Extra-Low Voltage (SELV) (Europe)
Power Consumption	14 VA maximum for IOM1711 or IOM2711 only <b>Note:</b> VA rating does <b>not</b> include any power supplied to the peripheral devices connected to Binary Outputs (BOs) or Configurable Outputs (COs), which can consume up to 12 VA for each BO or CO; for a possible total consumption of an additional 84 VA (maximum).
Ambient Conditions	<b>Operating:</b> 0° to 50°C (32° to 122°F); 10% to 90% RH noncondensing <b>Storage:</b> -40° to 80°C (-40° to 176°F); 5% to 95% RH noncondensing
Addressing	DIP switch set; valid controller device addresses 4–127 (Device addresses 0–3 and 128–255 are reserved and not valid controller addresses.)
Communications Bus	<b>BACnet® MS/TP, RS-485:</b> 3-wire FC Bus between the supervisory controller and other controllers 4-wire SA bus between controller, network sensors and other sensor/actuator devices, includes a lead to source 15 VDC supply power (from controller) to bus devices.
Processor	H8SX/166xR Renesas® 32-bit microcontroller
Memory	512 KB Flash Memory and 128 KB Random Access Memory (RAM)

**Table 9: IOM1711 and IOM2711 Technical Specifications**

<p><b>Input and Output Capabilities</b></p>	<p><b>IOM1711:</b>  <b>4 - Binary Inputs:</b> Defined as Dry Contact Maintained or Pulse Counter/Accumulator Mode.</p> <p><b>IOM2711:</b>  <b>2 - Universal Inputs:</b> Defined as 0–10 VDC, 4–20 mA, 0–600k ohm, or Binary Dry Contact  <b>2 - Universal Outputs:</b> Defined as 0–10 VDC, 4–20 mA, or 24 VAC/DC Field-Effect Transistor (FET) BO                  2 - Relay Outputs: (Single-Pole, Double-Throw)  <b>UL Listed (-0 model only)</b>                  1/4 hp 120 VAC, 1/2 hp 240 VAC                  360 VA Pilot Duty at 120/240 VAC (B300)                  3 A Non-inductive 24-240 VAC  <b>CE Marking (-2 model only):</b> 6 (4) A N.O. or N.C. only, 240 VAC</p>
<p><b>Analog Input/Analog Output Resolution and Accuracy</b></p>	<p><b>Input:</b> 16-bit resolution  <b>Output:</b> 16-bit resolution, +/- 200 mV accuracy in 0-10 VDC applications</p>
<p><b>Terminations</b></p>	<p><b>Input/Output:</b> Fixed Screw Terminal Blocks  <b>SA/FC Bus and Supply Power:</b> 4-Wire and 3-Wire Pluggable Screw Terminal Blocks  <b>SA/FC Bus Port:</b> RJ-12 6-Pin Modular Jacks</p>
<p><b>Mounting</b></p>	<p>Horizontal on single 35 mm DIN rail mount (preferred), or screw mount on flat surface with three integral mounting clips on controller</p>
<p><b>Housing</b></p>	<p>Enclosure material: ABS and polycarbonate UL94 5VB; Self extinguishing, Plenum Rated                  Protection Class: IP20 (IEC529)</p>
<p><b>Dimensions(Height x Width x Depth)</b></p>	<p>150 x 120 x 53 mm (5-7/8 x 4-3/4 x 2-1/8 in.) including terminals and mounting clips  <b>Note:</b> Mounting space requires an additional 50 mm (2 in.) space on top, bottom and front face of controller for easy cover removal, ventilation and wire terminations.</p>
<p><b>Weight</b></p>	<p>0.5 kg (1.1 lb) maximum</p>

**Table 9: IOM1711 and IOM2711 Technical Specifications**

<b>Compliance</b>	<b>United States:</b> UL Listed, File E107041, CCN PAZX, UL Listed, Energy Management Equipment; FCC Compliant to CFR47, Part 15, Subpart B, Class A <b>Note:</b> Except IOM2711-2
	<b>Canada:</b> UL Listed, File E107041, CCN PAZX7 CAN/CSA C22.2 No.205, Signal Equipment; Industry Canada Compliant, ICES-003 <b>Note:</b> Except IOM2711-2
	<b>Europe:</b> Johnson Controls, Inc. declares that these products are in compliance with the essential requirements and other relevant provisions of the EC Directive and Low Voltage Directive. Declared as Independently Mounted, Intended for Panel Mounting, Operating Control Type 1.B, 4kV rated impulse voltage, 100.7°C ball pressure test. <b>Note:</b> Except IOM2711-0
	<b>Europe:</b> Johnson Controls, Inc. declares that this product is in compliance with the essential requirements and other relevant provisions of the EC Directive. <b>Note:</b> Except IOM2711-0
	<b>Australia and New Zealand:</b> RCM Mark, Australia/NZ Emissions Compliant <b>Note:</b> Except IOM2711-0
	<b>BACnet International:</b> BACnet Testing Laboratories (BTL) Protocol Revision 4 Listed BACnet Application Specific Controller (B-ASC)

*The performance specifications are nominal and conform to acceptable industry standard. For application at conditions beyond these specifications, consult the local Johnson Controls® office. Johnson Controls, Inc. shall not be liable for damages resulting from misapplication or misuse of its products.*

**European Single Point of Contact:**

JOHNSON CONTROLS  
WESTENDHOF 3  
45143 ESSEN  
GERMANY

**NA/SA Single Point of Contact:**

JOHNSON CONTROLS  
507 E MICHIGAN ST  
MILWAUKEE WI 53202  
USA

**APAC Single Point of Contact:**

JOHNSON CONTROLS  
C/O CONTROLS PRODUCT MANAGEMENT  
NO. 22 BLOCK D NEW DISTRICT  
WUXI JIANGSU PROVINCE 214142  
CHINA



**Building Efficiency**  
507 E. Michigan Street, Milwaukee, WI 53202

*Johnson Controls® is a registered trademark of Johnson Controls, Inc.  
All other marks herein are the marks of their respective owners. © 2016 Johnson Controls, Inc.*