

M100G Series Proportional Actuator with VDC/mA Control Input R81GAA-2 Interface Board

The M100G Series actuator is used in applications where dampers or valves are to be modulated open or closed. Typical applications include positioning a CD-1300 Series damper; opening and closing a diverting valve; positioning a hot water, chilled water, or steam valve; controlling an inlet vane damper on a fan, outdoor air, return air, and exhaust dampers; face and bypass control; and blade positioning for variable volume fans.

The R81GAA-2 electronic circuit board in the actuator accepts a proportional 0 to 10 VDC or 4 to 20 mA control signal. The control signal is jumper selectable for Direct Action (DA) or Reverse Action (RA).

Refer to damper manufacturer's information to properly size the damper and actuator. Return-to-normal spring return actuators are recommended for use with outdoor air dampers.

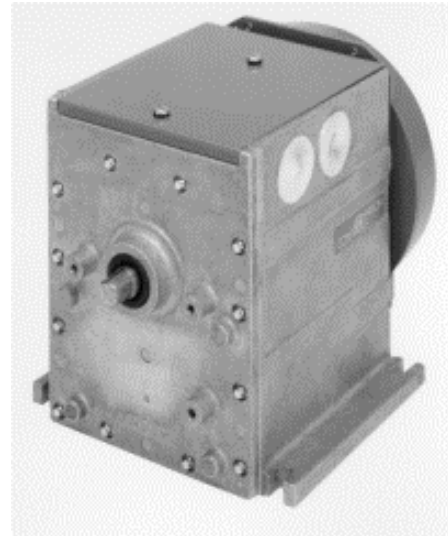

Figure 1: M100G Series Proportional Actuator

Features and Benefits	
<input type="checkbox"/> Auxiliary Output Shaft	Allows use of accessories and linkage connections for dampers
<input type="checkbox"/> Load Versatility	Available in torques of 25, 35, 50, 75, and 150 lb·in (2.8, 4.0, 5.7, 8.5, and 17 N·m)
<input type="checkbox"/> Travel Adjustment Located in Top Wiring Compartment	Makes adjustment easy and reduces installation time
<input type="checkbox"/> Plug-in Electronic Interface Boards	Allows faster replacement or conversions, shorter service times, and reduces inventory

Operation

IMPORTANT: All M100G Series actuators are intended to control equipment under normal operating conditions. Where failure or malfunction of M100G actuators could lead to an abnormal operating condition that could cause personal injury or damage to the equipment or other property, other devices (limit or safety controls) or systems (alarm or supervisory) intended to warn of, or protect against, failure or malfunction of M100G actuators must be incorporated into and maintained as part of the control system.

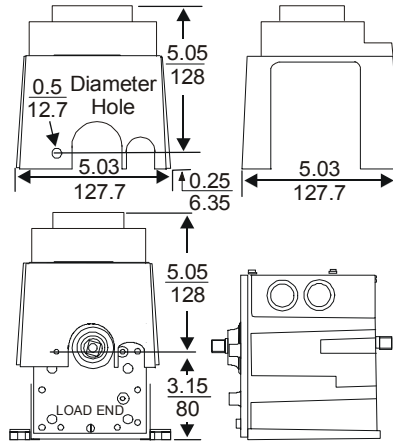

Figure 2: CVR83A-600R Dimensions, in. (mm)

The M100G proportional actuator is factory set for DA with a 4 to 20 mA input signal for 90° travel.

Dimensions

Dimensions for a CVR83A-600R Weather Cover Kit are shown in Figure 2, an actuator and a switch kit in Figure 3, and a spring return actuator in Figure 4. Allow additional space for the optional cover-mounted transformer (2.5 in. [63.5 mm] height), and the switch kit (2 in. [50.8 mm] length at the auxiliary end).

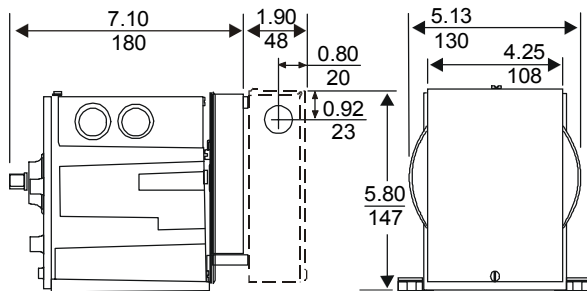

Figure 3: Spring Return with Switch Kit Dimensions, in. (mm)

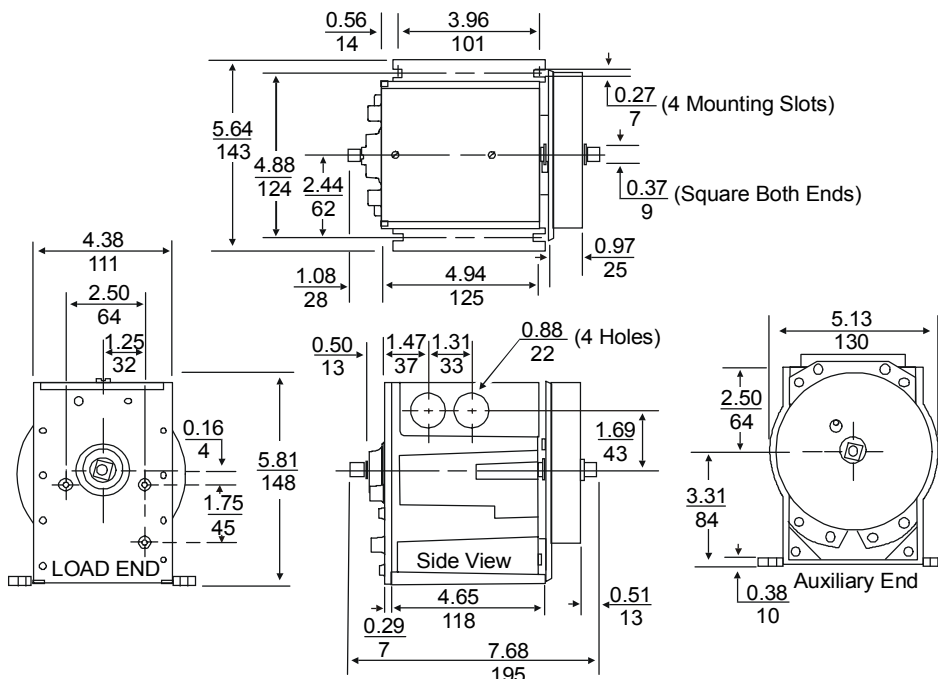

Figure 4: M100 with Spring Return Dimensions, in. (mm)

Repair and Replacement

The drive motor and gear train are immersed in oil and sealed in a die cast case, so maintenance is not necessary. Make no field repairs, except to replace the R81G electronics kit.

Ordering Information

Specify code number R81-GGA-2 to order an electronics kit. Refer to Table 1 or Table 2 for the product code for an actuator or accessory, and contact the nearest Johnson Controls representative.

Table 1: M100G Actuators

Product Code	Description
M110GGA-3	25 lb-in (2.8 N·m) torque, spring return, 24 VAC, VDC/mA input and adjustable zero and span
M120GGA-3	35 lb-in (4.0 N·m) torque, non-spring return, 24 VAC, VDC/mA input and adjustable zero and span
M130GGA-3	50 lb-in (5.6 N·m) torque, spring return, 24 VAC, VDC/mA input and adjustable zero and span
M140GGA-3	75 lb-in (8.5 N·m) torque, non-spring return, 24 VAC, VDC/mA input and adjustable zero and span
M150GGA-3	150 lb-in (17.0 N·m) torque, non-spring return, 24 VAC, VDC/mA input and adjustable zero and span
M110XGA-1*	25 lb-in (2.8 N·m) torque, spring return
M120XGA-1*	35 lb-in (4.0 N·m) torque, non-spring return
M130XGA-1*	50 lb-in (5.6 N·m) torque, spring return
M140XGA-1*	75 lb-in (8.5 N·m) torque, non-spring return
M150XGA-1*	150 lb-in (17 N·m) torque, non-spring return

* Requires the R81G electronics kit.

Table 2: Accessories

Product Code	Description
Y68AA-1	Transformer, 120/24 VAC, 40 VA, 60 Hz, Class 2
Y68DA-1	Transformer, 240/24 VAC, 40 VA, 60 Hz, Class 2
Y68HA-1	Transformer, 24/24 VAC, 40 VA, 60 Hz, Class 2
S91DJ-1	Auxiliary switch kit with one Single-Pole, Double-Throw (SPDT) switch
S91EJ-1	Auxiliary switch kit with two SPDT switches
S91PT-1	Auxiliary potentiometer kit, 1000 ohm, 1/3 watt
CVR83A-600R	Weather cover kit
Y20DAA-2	Mounts actuator to top of duct or any flat surface; includes LVR27A-602, LVR27A-600, ROD16-3, and SWL10A-603Y (2)
Y20DAB-2	Mounts the actuator to the side of a duct or wall; includes all items in the Y20DAA-2 plus one BKT22A-602
Y20EBA-1	Valve linkage kit for mounting Honeywell® valves with 1/4-28 stem connection to M120 or M130 actuators
Y20EBA-2	Valve linkage kit for mounting Honeywell valves with 1/4-28 stem connection to M150 actuators
Y20EBA-3	Valve linkage kit for mounting Barber-Coleman® valves with 1/4-28 stem connection to M120 or M130 actuators
Y20EBA-4	Valve linkage kit for mounting Barber-Coleman valves with 1/4-28 stem connection to M150 actuators
Y20EBD-1	Linkage kit for M120 or M130 actuators and 1-1/4 in. (DN 32) valves, produces 75 lb (334 N) seating force
Y20EBD-2	Linkage kit for M140 actuators and 1-1/4 in. (DN 32) valves, produces 150 lb (607 N) seating force
Y20EBD-3	Linkage kit for M150 actuators and 1-1/4 in. (DN 32) valves, produces 270 lb (1202 N) seating force
Y20EBD-5	Linkage kit for M110 actuators and 1-1/4 in. (DN 32) valves, produces 40 lb (178 N) seating force
Y20EBD-6	Linkage kit for M120 or M130 actuators and 1-1/4 in. (DN 32) valves, produces 100 lb (449 N) seating force
Y20EBE-1	Coupling adaptor to convert valves with a 5/16 in. stem and a hold down nut for Johnson Controls 1/2 to 3 in. valves manufactured prior to March 1969
Y20EBE-2	Stem adaptor and centerpiece collar to adapt VT Series valves with slotted stems (Y20EBD-5 kit also required)
Y20EBE-3	Hold down nut for cast iron and VB Series 2-1/2 to 4 in. valves, yoke nut for Barber-Coleman 1/2 to 2 in. valves
Y20EBE-4	Stem connector for Barber-Coleman 2-1/2 to 4 in. valves (5 per package) used with Y20EBD-3 or Y20EBD-6
Y20EBE-11	Valve linkage adaptor kit for VG7000 valves (Y20EBD Series kit also required)
VG7000-M110	Mounting kit for M110 actuator and 1/2 through 2 in. (DN15 through DN50) valves
VG7000-M130	Mounting kit for M130 actuator and 1/2 through 2 in. (DN15 through DN50) valves
VG7000-M140	Mounting kit for M140 actuator and 1/2 through 2 in. (DN15 through DN50) valves
VG7000-M150	Mounting kit for M150 actuator and 1/2 through 2 in. (DN15 through DN50) valves
Y20DFC-1	Damper linkage kit for mounting the actuator to the inside or outside frame of CD-1300 dampers only

Specifications

Product	M100G Series Proportional Actuator with VDC/mA Control Signal Input R81GAA-2 Interface Board		
Power Requirements	24 VAC, Class 2 (20 to 30 VAC) at 50/60 Hz, 25 VA spring return, 20 VA non-spring return		
Input Signal	0 to 24 VDC, 0 to 20 mA with 500 ohm resistor; factory calibrated 4.0 to 19.6 mA		
Input Signal Adjustments	Direct Acting (DA) or Reverse Acting (RA) operation Zero: Adjustable 0.25 to 24 VDC Span: Adjustable 2.00 to 18 VDC		
Mechanical Connection	3/8 in. (9.5 mm) square shaft, both ends Maximum dead weight on output shaft: 200 lb (91 kg), load end; 10 lb (4.5 kg), auxiliary end		
Mechanical Output	Running Torque	Breakaway and Stall (minimum)	
	M110	25 lb·in (2.8 N·m) spring return	100 lb·in (11 N·m)
	M120	35 lb·in (4.0 N·m)	70 lb·in (7.9 N·m)
	M130	50 lb·in (5.6 N·m) spring return	200 lb·in (23 N·m)
	M140	75 lb·in (8.5 N·m)	150 lb·in (17 N·m)
	M150	150 lb·in (17 N·m)	300 lb·in (34 N·m)
Rotation Range	Fixed zero, adjustable full travel 65 to 270°; factory set at 90° full travel		
Input Impedance	44,000 ohms		
Rotation Timing (at Rated Load)	60 seconds for 160° travel nominal, 60 Hz 38 seconds for 90° travel nominal, 60 Hz 75 seconds for 90° spring return		
Cycle Life	M110 and M130 spring return models:	150,000 cycles at rated load	
	M120, M140, and M150 non-spring return models:	200,000 cycles at rated load	
Electrical Connection	1/4 in. quick-connect spade terminals		
Action	Clockwise rotation on increasing signal (DA) and counterclockwise rotation on increasing signal (RA); factory set for DA		
Ambient Operating Conditions	Spring Return:	-35 to 125°F (-37 to 52°C), 90% RH	
	Non-spring Return:	-40 to 125°F (-40 to 52°C), 90% RH	
Ambient Storage Conditions	-40 to 140°F (-40 to 60°C), 90% RH		
Dimensions (H x W x D)	Spring Return:	5.81 x 5.64 x 7.68 in. (148 x 143 x 195 mm)	
	Non-spring Return:	5.81 x 5.64 x 4.94 in. (148 x 143 x 125mm)	
Shipping Weight	Spring Return:	9 lb (4.1 kg)	
	Non-spring Return:	6.5 (2.9 kg)	
Enclosure	NEMA 2, IP32		
Agency Compliance	M1x0GGA is UL Recognized, File E27734, CCN XAPX2 M1x0GGA is UL Listed, File E107041, CCN PAZX CSA Certified, File LR948, Class 4813 02		
EU Directive Compliance	89/336/EEC (CE Mark), M1x0GGA models only		

The performance specifications are nominal and conform to acceptable industry standards. For application at conditions beyond these specifications, consult the local Johnson Controls office. Johnson Controls, Inc. shall not be liable for damages resulting from misapplication or misuse of its products.



Controls Group
507 E. Michigan Street
P.O. Box 423
Milwaukee, WI 53202

Printed in U.S.A.
www.johnsoncontrols.com